

PF7906



EXPLORA COLOMBO COMBI OVEN 6 TRAYS 600X400 - GN 1/1

rev: PF7906_P15



Load Capacity		n°6 - EN 600x400 - GN 1/1
Space between trays		80 mm
Cooking chamber dimensions - Gross volume		66x45x56 cm - 166 lit
WxDxH - Width x Depth x Height		78x85x83 cm
Nominal power	kW	10.5 kW
Heating power		2x5000W @230V
Motor power		2x250W @230V
N° motor speed phases		8
Reverse		Balanced Reverse
Nominal voltage		400V 3N~
Nominal Current		22/22/2/19 A
Suggested cross section cable		5x2.5 mm ²
Frequency		50/60 Hz
Cooking phases		40
N° cooking programs		99
Cooking chamber material	AISI	Inox AISI304
Timer		0 - 24h
Core probe		1x
Automatic washing system		•
Humidity/Steaming		Sator steam
Fast cooling		•
Temperature		30 - 270 °C
Pre-heating		270 °C
Rapid steam evacuation		Optimal climatic
Waterproof level		IPx4
Net weight		90 kg
WixDixHi - Width x Depth x Height - Package		85x103x99 cm



PF7906



EXPLORA COLOMBO COMBI OVEN 6 TRAYS 600X400 - GN 1/1

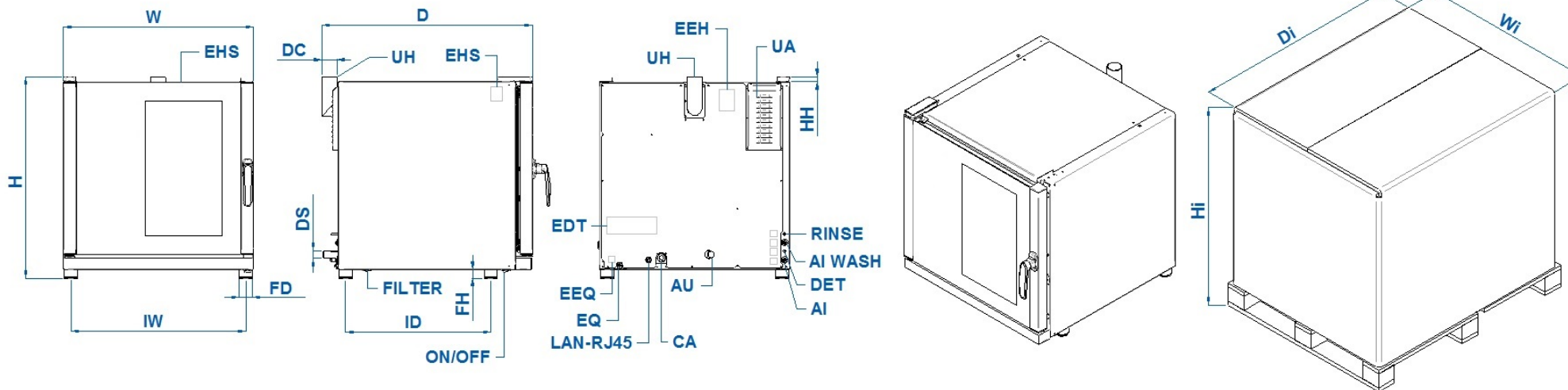

- UH** - Exhaust hot fumes
- UA** - Cooling air exit
- CA** - Power Cord
- EQ** - Equipotential terminal
- EHS** - Hot surface label
- EDT** - Datasheet label
- AI** - Water in

- AU** - Water out
- EAI** - Water in label
- UC** - Non-return valve
- RF** - Junction Ø8 - 3/4
- RG** - Junction Ø8 - Ø8 90°
- EEQ** - Equipotential label
- EHH** - Exhaust hot fumes label

- IW** : 70 cm
- ID** : 58 cm
- FD** : Ø 5,2 cm
- FH** : 3,5 cm
- DC** : Ø 6 cm
- HH** : 2 cm
- DS** : Ø 3 cm

- Wheelbase feet - width
- Wheelbase feet - deep
- Ø feet
- Feet height
- Ø exhaust pipe
- Hinge height
- Ø water out pipe

PF7906



EXPLORA COLOMBO COMBI OVEN 6 TRAYS 600X400 - GN 1/1

